

NO.	DATE	REVISION DESCRIPTION	DR.	CK.

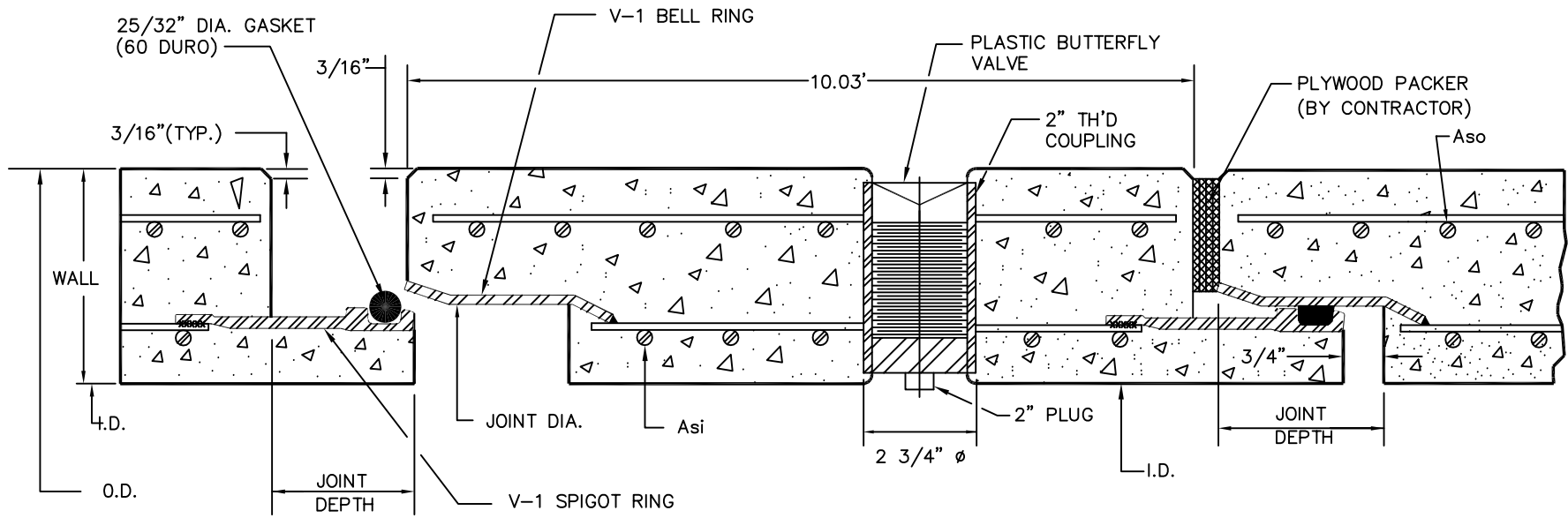

**2" GROUT HOLE DETAIL
(WITH PLUG)**

NOTES:

1. MINIMUM $f'c = 6,000$ psi
2. PIPE IS AVAILABLE IN DIAMETERS 42" AND GREATER
3. BELL RINGS MEET REQUIREMENTS FOR A36 STEEL.
4. SPIGOT RINGS MEET REQUIREMENTS FOR A576 STEEL.
5. WIRE MESH CONFORMS TO ASTM A 185 ($F_y = 65$ PSI)
6. GASKETS MEET REQUIREMENTS OF AWWA C302.

VIANINI PIPE, INC.

REINFORCED CONCRETE JACKING PIPE
W/RUBBER & STEEL JOINTS (V1-JP)